

Goodrive290 Series

Low-Voltage Multifunction General-Purpose VFD





Contents

Company introduction.....	2
Product introduction.....	4
Product application.....	5
Product features.....	6
Technical specifications.....	9
Naming rule.....	10
Product selection.....	11
Expansion card selection.....	12
Accessory selection.....	12
Reactor&filter selection.....	13
Wiring diagram.....	14
Installation method.....	15

INVT (Shenzhen INVT Electric Co., Ltd) has been concentrating on industry automation and energy power since its foundation in 2002 and is committed to "Providing the best product and service to allow customers more competitiveness". INVT goes public in 2010 and is the first A-share listed company (002334) in Shenzhen Stock Exchange in the industry. At present, INVT owns 15 subsidiaries and more than 4500 employees, over 40 branches, forming a sales network covering more than 100 overseas countries and regions.

INVT has been awarded as the Key High-tech Enterprise of National Torch Plan based on mastering of key technologies in power electronics, auto control and IT. With business covering industry automation, electric vehicle, network power and rail transit, INVT has established 10 R&D centers nationwide, boasts more than 1400 patents and owns the first lab in the industry awarded ACT qualification from TÜV SÜD, UL-WTDP and CNAS National Lab. The industrial parks in Shenzhen and Suzhou aim to provide customers with advanced integrated product development design management, comprehensive product R&D test and auto informational production. The worldwide INVT branches and warranty service centers are ready to offer customers all-around back-ups including professional solutions, technical trainings and service support.

In the next decade, INVT will continue to take " Sincere Virtuous, Professional Aspiring" as our business philosophy, enhance core business sectors including industrial automation, electric vehicle, network power and rail transit based on the three major technologies in industry automation and energy power fields, and strive to become a leading, responsible and harmonic international professional group armed with proper product structure, leading technologies, efficient management, robust profitability and superior competitiveness.



COMPANY PROFILE



Product introduction

GD290 series VFD is a low-voltage multifunction general-purpose VFD with a power range from 0.75kW to 1200kW (380–480V). It delivers robust performance in driving asynchronous motors and can be widely applicable to constant torque and variable torque load equipment across various industries such as municipal engineering, chemical processing, HVAC, textiles, food, and packaging.



Easy to use

- Compact book-style design; T10–T13 frames adopt a roller-type structure; built-in braking units up to 110kW are supported, saving installation space and labor time and reducing cabinet assembly costs.
- Supports 24V power supply cards and LCD keypads, making commissioning safe, intuitive, and easy to operate.
- Supports a wide range of industrial bus communication expansions and I/O expansions, including PROFINET, PROFIBUS-DP, Modbus TCP, and CANopen; features grid voltage and frequency selection. G-type models are available up to 1000kW, and P-type models up to 1200kW, enabling one VFD to efficiently meet diverse requirements.
- Built-in dedicated water supply functions such as multi-pump rotation reduce manual intervention and extend the service life of water pumps.



Reliable and durable

- Wide 380–480V input voltage design provides strong resistance to grid fluctuations.
- Independent air duct design, thickened conformal coating, and support for dustproof cover plates (for T3–T6 frames) effectively protect against dust and corrosive gas environments, improving equipment operating reliability.
- High-power models are supplied as standard with built-in C3 filters for T9–T15 frames and reactors for T12–T15 frames, improving EMC performance and optimizing the power factor.
- Two-year warranty; compliant with the RoHS Directive, and CE- and EAC-certified, providing reliable assurance and meeting requirements for overseas markets.



Energy efficient

- Equipped with an ECO energy-saving control algorithm to dynamically match load demand and effectively reduce energy consumption during no-load and light-load operation.
- Supports intelligent sleep mode, enabling start/stop on demand and optimizing energy efficiency throughout the equipment lifecycle.

/ Product application

District heating >>>



Wastewater treatment >>>



HVAC >>>



Plastic machinery >>>



Food processing >>>



Paper production equipment >>>



Product features



Rich functionality

- Multi-step speed setting function:** Enables 16-step speed settings through combinations of 4 terminals to meet process-specific speed requirements.

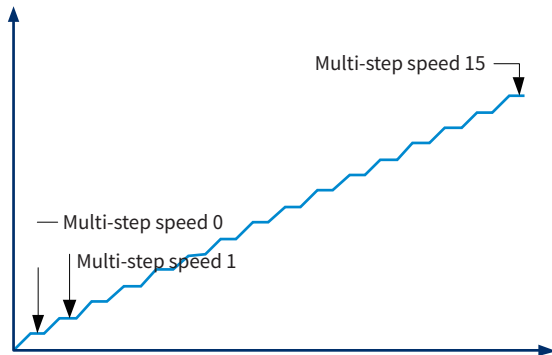

- Speed tracking function:** Reduces device impact and enhances restart performance by tracking the device rotation speed.

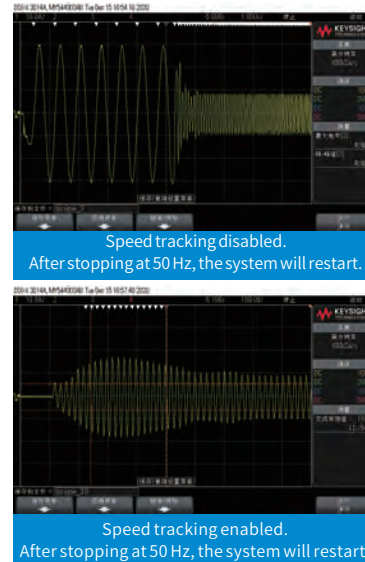

- Ride-through function:** Ensures continuous operation during short-term power grid fluctuations, preventing unexpected shutdowns.



- Regeneration avoidance:** When the system is in a light regenerative state, the output frequency is automatically increased to prevent over voltage alarms, ensuring stable machine running.

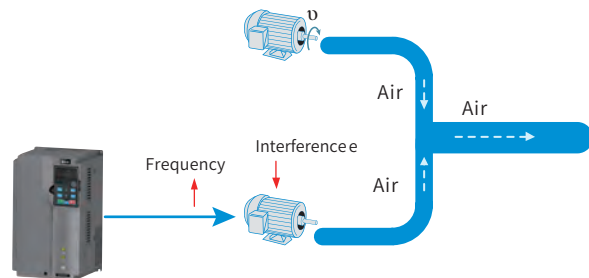

- Restart after power failure:** The automatic restart function after power failure can be selected, with no restart command required.

- Multi-pump alternation and auxiliary pump start/stop functions:** Supports alternating operation of variable frequency pumps for water supply, fixed frequency pump water supply, and sleep control (Note: Relay card configuration is required)

If no specific pump is designated as the variable frequency pump, and the water supply pressure is insufficient, the running variable frequency pump will switch to grid frequency operation. The variable frequency control will then switch to the next pump as the variable frequency pump (up to 8 variable frequency pumps can be controlled; only one variable frequency pump can operate at a time).

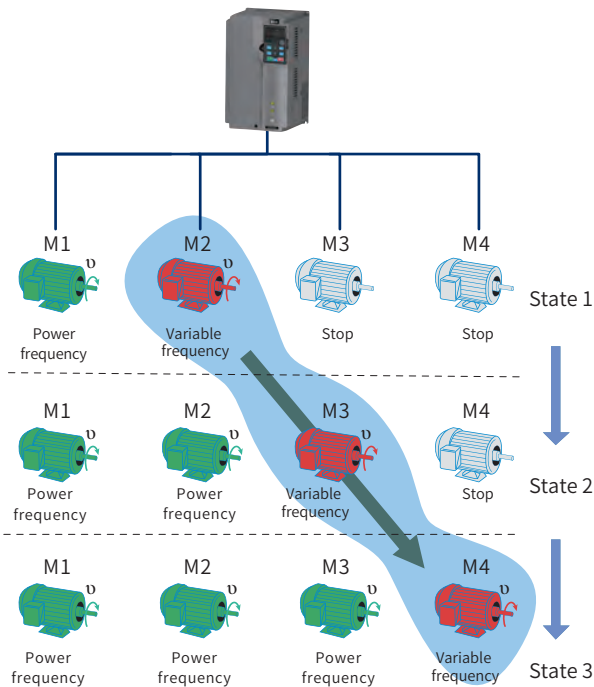

- ECO mode:** Ensures optimal performance and minimum loss at low dynamic loads, optimizing output power.

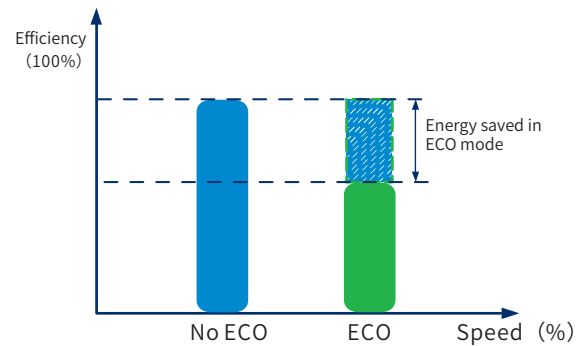

Energy saving effect (annual)	Condition
Annual energy saving: Approx. 8100kWh	<ul style="list-style-type: none"> Applicable to 4kW IE2 asynchronous motors Load rate: 40% Number of units: 10 units Annual operation days: 24 hours/365 days Control, energy saving mode: V/F, maximum efficiency mode Energy saving gain coefficient: 100% Energy saving angle compensation coefficient: 80%
<small>Note: Internal measurement data. Actual energy savings may vary depending on the motor's characteristics and performance.</small>	<small>Only effective for asynchronous motor control and V/F control. It is recommended to enable this function in fan and pump applications where load variations are minimal.</small>

- Energy saving control:** Avoids frequent starts and stops, enabling sleep mode at night or energy-efficient operation under very low loads.

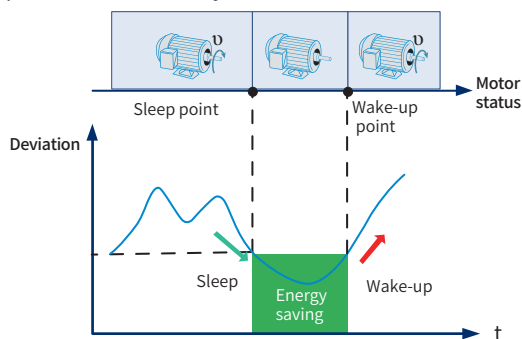



Strong expandability

- **Dual expansion channels:** Can simultaneously meet two different types of expansion requirements.

1	Optional I/O expansion card	Allows for the expansion of digital and analog input/output terminals as well as relay terminals.
2	Optional communication expansion card	Supports various industrial fieldbuses such as PROFINET, PROFIBUS-DP, and CANopen.
3	Optional 24V power supply card	Enables parameter read/write through communication or keypad even when the main power supply is off.

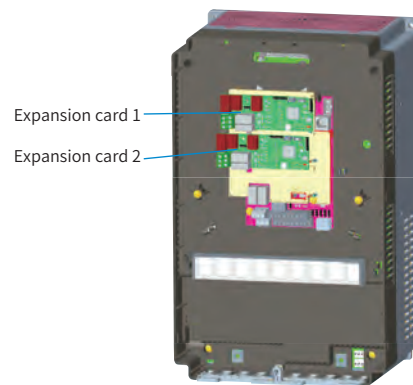

Reliable and environmentally friendly

- **Independent air duct design:** Effectively improves the protection of the VFD, preventing dust from entering the VFD's interior, avoiding faults such as short circuits. It also helps expel internal heat, solving the machine's cooling issues, enhancing reliability, and extending the VFD's lifespan.

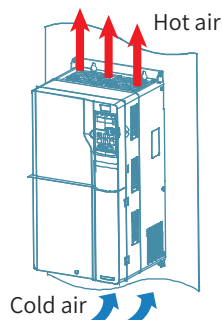

- **Enhanced PCB coating:** Strengthens the three-proof treatment, improving the PCB's protective capability. The board is more resistant to harsh environments, ensuring the VFD operates healthily for an extended lifespan.



- **CE and EAC certified**

- **Compliant with RoHS:** Standard products comply with the RoHS Directive (EU Specific Restriction of Hazardous Substances)

Technical specifications

	Function	Specifications
Technical control performance	Input voltage (V)	AC 3PH 380–480V, rated voltage: 380V
	Allowed voltage transient fluctuation	-15%~+10%
	Input frequency (Hz)	50Hz or 60Hz; Allowed range: 47–63Hz
	Output frequency (Hz)	0–400Hz
	Control mode	Space voltage vector control, and sensorless vector control (SVC)
	Motor type	Asynchronous motor (AM)
	Speed ratio	For AM: 1:200 (SVC)
	Speed control accuracy	±0.2% (SVC)
	Speed fluctuation	±0.3% (SVC)
	Torque response	<20ms (SVC)
	Torque control accuracy	±10% (SVC)
Overload capacity	For G type: 150% for 1min, 180% for 10s, with overload allowed once every 5min. For P type: 110% for 1min, with overload allowed once every 5min.	
Running control performance	Frequency setting method	Supports keypad digital setting, analog setting, multi-step speed running setting, simple PLC setting, PID setting, communication setting, and so on. These settings can be combined and the setting channels can be switched.
	Automatic voltage regulation	The output voltage can be kept constant although the grid voltage changes.
	Fault protection	Various protection functions, such as protection against overcurrent, overvoltage, undervoltage, overtemperature, phase loss, and overload.
	Speed tracking restart function	Enables smooth startup of a rotating motor.
Peripheral interface	Analog input	Two inputs. AI1: 0(2)–10V / 0(4)–20mA; AI2: -10~+10V
	Analog output	Two outputs. AO0/AO1: 0(2)–10V/0(4)–20mA
	Digital input	Five regular inputs. Max. frequency: 1kHz; internal impedance: 3.3kΩ One high-speed input, max frequency 50kHz
	Digital output	One Y terminal open collector output, sharing the terminal with S4. The function can be selected through a jumper.
	Relay output	Two programmable relay outputs RO1A: NO; RO1B: NC; RO1C: common RO2A: NO; RO2B: NC; RO2C: common Contact capacity: 3A/AC 250V, 1A/DC 30V
	Expansion interfaces	Two expansion interfaces, SLOT1 and SLOT2, supporting communication cards and I/O cards.
Other	Mounting method	T1–T10 frames support wall mounting. T1–T9 frames support flange mounting. T10–T15 frames support floor mounting.
	Keypad configuration	T1–T4 frames are equipped with a membrane LED keypad as standard. T5–T12 frames are equipped with a remote-mountable LED keypad as standard.
	Operating ambient temperature	-10–50° C. Derating required above 40° C.
	Ingress protection (IP) rating	T1–T9 frames: IP20 T10–T13 frames: IP00 T14–T15 frames: IP21
	Pollution degree	Degree 2
	Cooling method	0R7G/1R5P: Natural cooling Other power ratings: Forced air cooling

Naming rule

GD290-045G/055P-4-X

Field description	Definition
Product series	GD290: Goodrive290 Series Low-Voltage Multifunction General-Purpose VFD
Power class + Load type	0.75-1200: Power class G: Constant torque load P: Variable torque load
Grid side voltage class	4: AC 3PH 380V-480V Rated voltage: 380V
Braking unit	X = B: optional built-in braking unit X = L3: optional built-in reactor.

Remarks:

Braking unit: T1-T5 frames are embedded with a braking unit as standard. T9-T15 frames: An external braking unit is optional.

G/P design explanation: For 132G/160P and below, G- and P-types are integrated; above that, they are separate.

L3 description: For T14 frame models, “-L3” indicates a standard built-in input reactor and an optional built-in output reactor.

Product selection







Frame	VFD model	Output power (kW)	Input current (A)	Output current (A)
T1	GD290-0R7G/1R5P-4	0.75/1.5	3.5/5	2.5/3.7
	GD290-1R5G/2R2P-4	1.5/2.2	4.5/6	3.7/5
	GD290-2R2G/003P-4	2.2/3	6/10.5	5/6.8
	GD290-003G/004P-4	3.0/4.0	10.5/15	6.8/9.5
T2	GD290-004G/5R5P-4	4/5.5	15/20	9.5/13
	GD290-5R5G/7R5P-4	5.5/7.5	20/27	14/17
T3	GD290-7R5G/011P-4	7.5/11	27/35	18.5/25
	GD290-011G/015P-4	11.0/15	35/44	25/32
T4	GD290-015G/018P-4	15/18.5	38/46	32/38
	GD290-018G/022P-4	18.5/22	46/54	38/45
T5	GD290-022G/030P-4	22/30	54/75	45/60
	GD290-030G/037P-4	30/37	72/90	57/75
T6	GD290-037G/045P-4(-B)	37/45	90/108	75/92
T7	GD290-045G/055P-4(-B)	45/55	108/142	92/115
	GD290-055G/075P-4(-B)	55/75	142/177	115/150
	GD290-075G/090P-4(-B)	75/90	177/200	150/180
T8	GD290-090G/110P-4(-B)	90/110	200/240	180/215
	GD290-110G/132P-4(-B)	110/132	220/278	205/250
T9	GD290-132G/160P-4	132/160	278/310	250/305
	GD290-160G-4	160	310	305
	GD290-185P-4	185	335	330
	GD290-200P-4	200	385	380
T10	GD290-185G-4	185	345	340
	GD290-200G-4	200	370	365
	GD290-220P-4	220	430	425
	GD290-250P-4	250	465	460
T11	GD290-220G-4	220	430	425
	GD290-250G-4	250	485	480
	GD290-280G-4	280	530	520
	GD290-280P-4	280	540	530
	GD290-315P-4	315	605	600
	GD290-355P-4	355	655	650
T12	GD290-315G-4	315	605	600
	GD290-355G-4	355	655	650
	GD290-400G-4	400	660	720
	GD290-400P-4	400	660	720
	GD290-450P-4	450	745	820
	GD290-500P-4	500	800	860
T13	GD290-450G-4	450	745	820
	GD290-500G-4	500	800	900
	GD290-560P-4	560	970	1020
	GD290-630P-4	630	1100	1120
T14	GD290-560G-4	560	970	1020
	GD290-560G-4-L3	560	970	1020
	GD290-630G-4	630	1100	1120
	GD290-630G-4-L3	630	1100	1120
	GD290-710P-4	710	1200	1260
	GD290-710P-4-L3	710	1200	1260
	GD290-800P-4	800	1320	1460
	GD290-800P-4-L3	800	1320	1460
T15	GD290-710G-4	710	1200	1260
	GD290-800G-4	800	1320	1460
	GD290-900P-4	900	1490	1640
	GD290-1000P-4	1000	1600	1720
	GD290-900G-4	900	1490	1640
	GD290-1000G-4	1000	1600	1720
	GD290-1120P-4	1120	1940	2040
	GD290-1200P-4	1200	2200	2240

Note: A product model suffixed with (-B) indicates that it supports an optional built-in braking unit.

Expansion card model selection

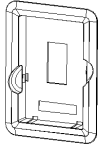
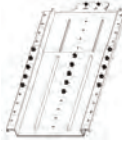
Expansion card type	Model	Name	Specifications
IO card	EC-IO501-00	I/O expansion card	Four digital inputs One digital output One analog input One analog output Two relay outputs One double-contact output, and one single-contact output.
	EC-IO503-00	Relay card	Two digital inputs Six relay outputs
Power supply card	EC-PS501-24	24V power supply expansion card	Input voltage range: DC18–30V(Rated 24VDC)/2A
Communication card	EC-TX509C	PROFINET communication card	Supporting the PROFINET protocol
	EC-TX503D	PROFIBUS-DP communication card	Supporting the PROFIBUS-DP protocol
	EC-TX505D	CANopen communication/CAN master-slave control communication card	CANopen communication or CAN master-slave control communication selectable through a DIP switch.
	EC-TX510B	Ethernet/IP & Modbus TCP communication card	Ethernet/IP communication or Modbus TCP communication selectable through a DIP switch.

Accessory selection

Accessory name	Appearance	Model/Function/ Applicable to	Accessory name	Appearance	Model/Function/ Applicable to
LCD keypad		Model: SOP-290 Function: Externally connected LCD display and operation panel Applicable to: All series	LED keypad		Model: BOP-270 Function: Externally connected LED display and operation panel Applicable to: T1–T4 frames Standard for T5–T15 frames.
Keypad bracket		Model: GD350-JPZJ Function: Used for external mounting on the electrical cabinet LED/LCD keypad Applicable to: All series	Rail assembly for cabinet installation		Model: GD270-DGZJ Function: Assists with internal cabinet installation, improving efficiency and safety Applicable to: T10–T13 frames
Flange mounting bracket		Model: Consult with manufacturer Function: Meets flange mounting requirements Applicable to: T1–T9 frames	Keypad dust cover		Model: GD270-JPFH Function: Prevents dust or foreign objects from entering the keypad opening when the keypad is mounted externally Applicable to: T5 and above frames.
Base		Model: Consult us Function: Raises the cabinet unit and reserves bottom wiring space, making on-site wiring easier Applicable to: T14–T15 frames	Ventilation dust cover		Model: Consult us Function: Prevents dust and foreign matter from entering the circuit board area Applicable to: T3–T6 frames

/ Reactor&filter selection

VFD power (kW)	Reactor		Filter	
	Input reactor	Output reactor	Input filter	Output filter
0.75	GDL-ACL0005-4CU	GDL-OCL0005-4CU	FLT-P04006L-B	FLT-L04006L-B
1.5	GDL-ACL0005-4CU	GDL-OCL0005-4CU	FLT-P04006L-B	FLT-L04006L-B
2.2	GDL-ACL0006-4CU	GDL-OCL0006-4CU	FLT-P04006L-B	FLT-L04006L-B
4	GDL-ACL0014-4CU	GDL-OCL0010-4CU	FLT-P04016L-B	FLT-L04016L-B
5.5	GDL-ACL0020-4CU	GDL-OCL0014-4CU	FLT-P04032L-B	FLT-L04032L-B
7.5	GDL-ACL0025-4CU	GDL-OCL0020-4CU	FLT-P04032L-B	FLT-L04032L-B
11	GDL-ACL0035-4AL	GDL-OCL0025-4CU	FLT-P04045L-B	FLT-L04045L-B
15	GDL-ACL0040-4AL	GDL-OCL0035-4AL	FLT-P04045L-B	FLT-L04045L-B
18.5	GDL-ACL0051-4AL	GDL-OCL0040-4AL	FLT-P04065L-B	FLT-L04065L-B
22	GDL-ACL0051-4AL	GDL-OCL0050-4AL	FLT-P04065L-B	FLT-L04065L-B
30	GDL-ACL0070-4AL	GDL-OCL0060-4AL	FLT-P04100L-B	FLT-L04065L-B
37	GDL-ACL0090-4AL	GDL-OCL0075-4AL	FLT-P04100L-B	FLT-L04100L-B
45	GDL-ACL0110-4AL	GDL-OCL0092-4AL	FLT-P04100L-B	FLT-L04100L-B
55	GDL-ACL0150-4AL	GDL-OCL0115-4AL	FLT-P04150L-B	FLT-L04150L-B
75	GDL-ACL0150-4AL	GDL-OCL0150-4AL	FLT-P04240L-B	FLT-L04150L-B
90	GDL-ACL0220-4AL	GDL-OCL0220-4AL	FLT-P04240L-B	FLT-L04240L-B
110	GDL-ACL0220-4AL	GDL-OCL0220-4AL	FLT-P04240L-B	FLT-L04240L-B
132	GDL-ACL0265-4AL	GDL-OCL0265-4AL	FLT-P04400L-B	FLT-L04400L-B
160	GDL-ACL0330-4AL	GDL-OCL0330-4AL	FLT-P04400L-B	FLT-L04400L-B
185	GDL-ACL0390-4AL	GDL-OCL0400-4AL	FLT-P04400L-B	FLT-L04400L-B
200	GDL-ACL0390-4AL	GDL-OCL0400-4AL	FLT-P04400L-B	FLT-L04400L-B
220	GDL-ACL0450-4AL	GDL-OCL0450-4AL	FLT-P04600L-B	FLT-L04600L-B
250	GDL-ACL0500-4AL	GDL-OCL0500-4AL	FLT-P04600L-B	FLT-L04600L-B
280	GDL-ACL0500-4AL	GDL-OCL0560-4AL	FLT-P04600L-B	FLT-L04600L-B
315	GDL-ACL0580-4AL	GDL-OCL0660-4AL	FLT-P04800L-B	FLT-L04800L-B
355	GDL-ACL0660-4AL	GDL-OCL0660-4AL	FLT-P04800L-B	FLT-L04800L-B
400	GDL-ACL0715-4AL	GDL-OCL0720-4AL	FLT-P04800L-B	FLT-L04800L-B
450	GDL-ACL0840-4AL	GDL-OCL0820-4AL	FLT-P041000L-B	FLT-L041000L-B
500	GDL-ACL1000-4AL	GDL-OCL1000-4AL	FLT-P041000L-B	FLT-L041000L-B

Remarks:

T12-T13 frames are supplied as standard with a built-in DC reactor. T14 frames are supplied as standard with a built-in input reactor, and a built-in output reactor is optional. T15 frames are supplied as standard with a built-in DC reactor and output reactor. For reactor or filter selection for 560kW and above models, consult us.

The preceding reactors and filters are external options.

For other option information, refer to the low-voltage VFD GDL series filter option brochure.

Wiring diagram

Main circuit wiring diagram >>>

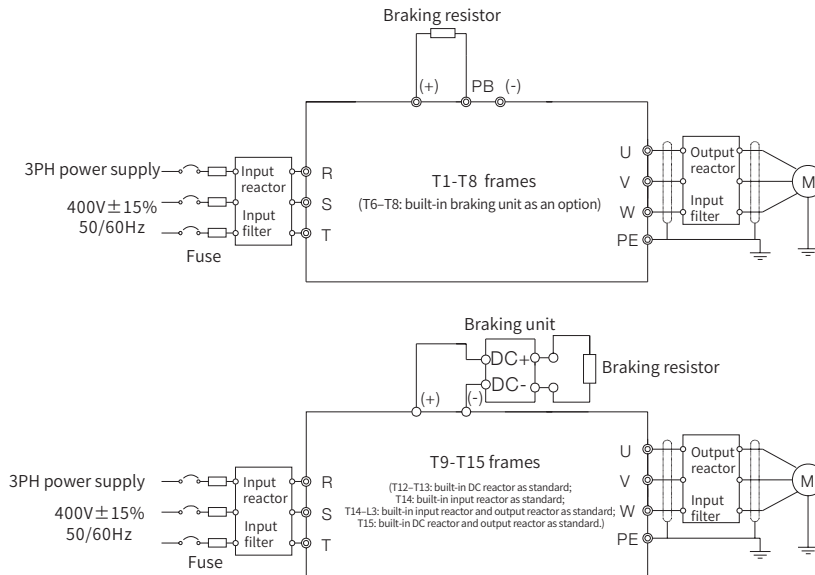

Control circuit wiring diagram >>>

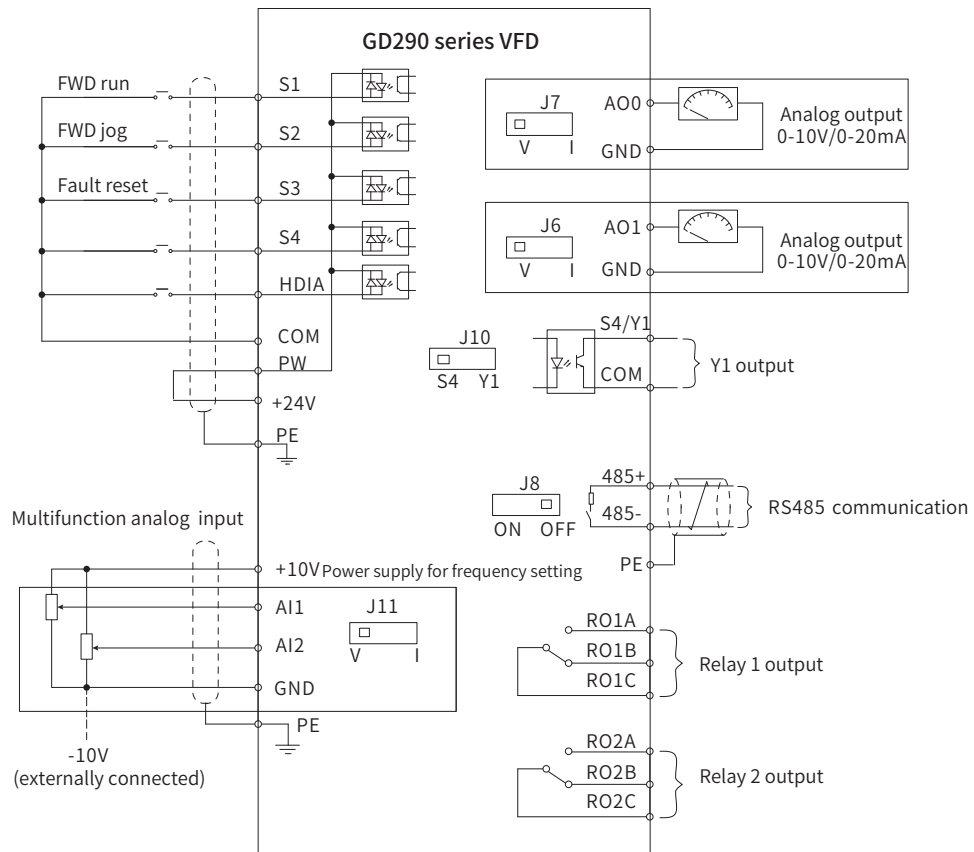

/ Installation method

Wall mounting >>>

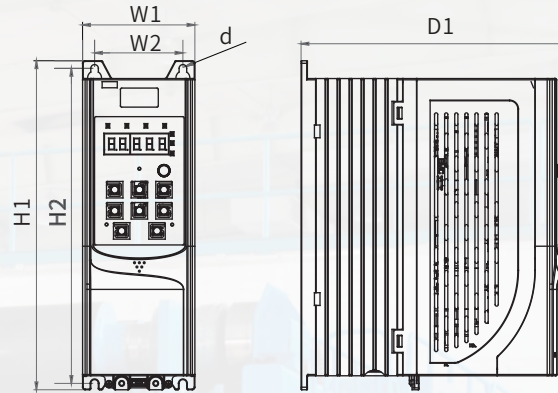

Wall mounting diagram for T1-T2 frames

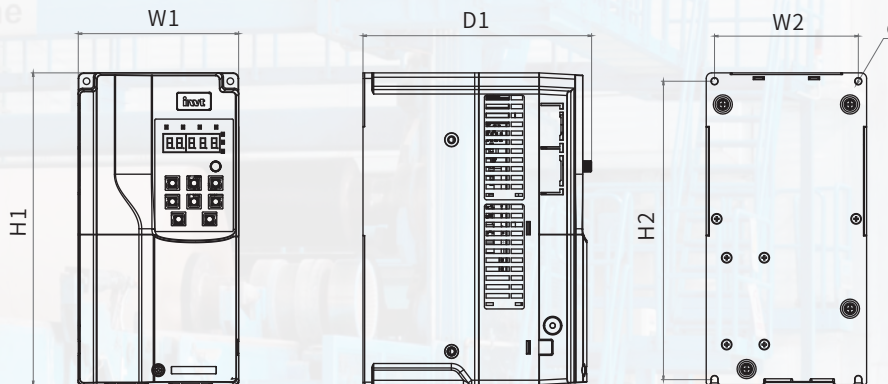

Wall mounting diagram for T3-T6 frames

(unit: mm)

Frame	VFD model	Outline dimensions (mm)			Hole distance (mm)			Hole diameter (mm)	Screw
		W1	H1	D1	H2	W2	D2		
T1	GD290-0R7G/1R5P-4	89	231	193	221	70	/	5	M4
	GD290-1R5G/2R2P-4								
	GD290-2R2G/003P-4								
	GD290-003G/004P-4								
T2	GD290-004G/5R5P-4	89	259	211.5	248	70	/	6	M5
	GD290-5R5G/7R5P-4								
T3	GD290-7R5G/011P-4	145	280	207	268	130	/	6	M5
	GD290-011G/015P-4								
T4	GD290-015G/018P-4	169	320	214	308	154	/	6	M5
	GD290-018G/022P-4								
T5	GD290-022G/030P-4	200	341	214	328.5	185	/	6	M5
	GD290-030G/037P-4								
T6	GD290-037G/045P-4(-B)	250	400	228	380	230	/	6	M5

Wall mounting >>>

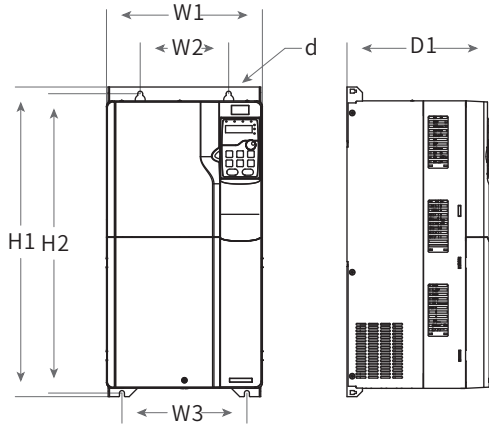

Wall mounting diagram for T7 frame

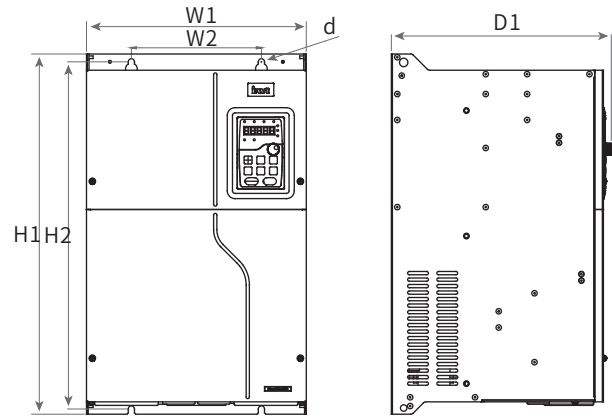

Wall mounting diagram for T8 frame

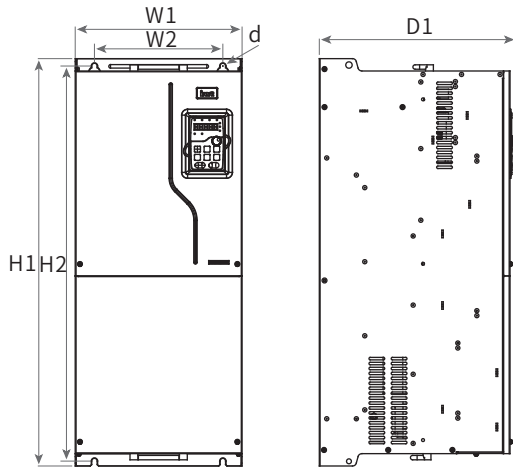

Wall mounting diagram for T9 frame

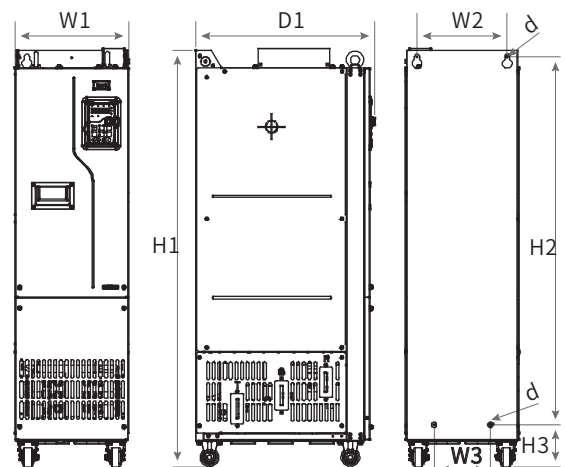

Wall mounting diagram for T10 frame

(unit: mm)

Frame	VFD model	Outline dimensions (mm)			Hole distance (mm)			Hole diameter (mm)	Screw
		W1	H1	D1	H2	W2	D2		
T7	GD290-045G/055P-4(-B)	282	560	264	542	160	226	5	M8
	GD290-055G/075P-4(-B)								
	GD290-075G/090P-4(-B)								
T8	GD290-090G/110P-4(-B)	338	554	338	534	200	/	9.5	M8
	GD290-110G/132P-4(-B)								
T9	GD290-132G/160P-4	338	825	398	800	260	/	11	M10
	GD290-160G-4								
	GD290-185P-4								
T10	GD290-200P-4	303	1108	477	980	240	240	14	M12
	GD290-185G-4								
	GD290-200G-4								
	GD290-250P-4								

Floor mounting >>>

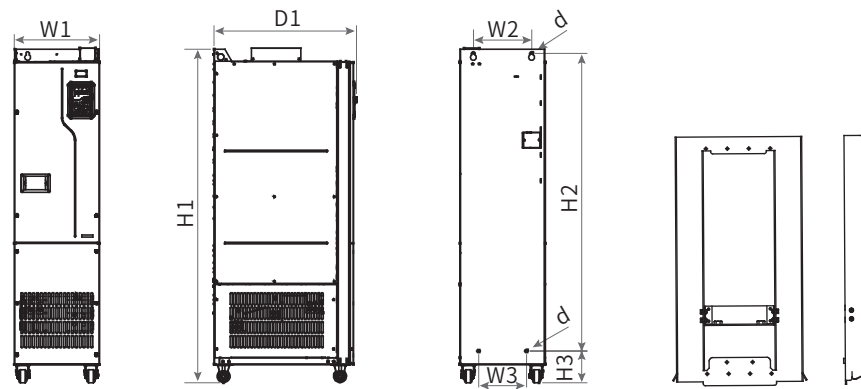

Floor mounting diagram for T10-T13 frames

(unit: mm)

Frame	VFD model	Outline dimensions (mm)			Hole distance (mm)			W3	Hole diameter (mm)	Screw
		W1	H1	D1	H2	H3	W2			
T10	GD290-185G-4	303	1108	477	980	111	240	150	14	M12
	GD290-200G-4									
	GD290-220P-4									
T11	GD290-220G-4	330	1288	552	1150	122	225	185	13	M10
	GD290-250G-4									
	GD290-280G-4									
	GD290-280P-4									
	GD290-315P-4									
T12	GD290-315G-4	330	1398	552	1280	101	240	200	13	M10
	GD290-355G-4									
	GD290-400G-4									
	GD290-400P-4									
	GD290-450P-4									
T13	GD290-500P-4	330	1450	582	1320	112	240	200	14	M12
	GD290-450G-4									
	GD290-500G-4									
	GD290-560P-4									

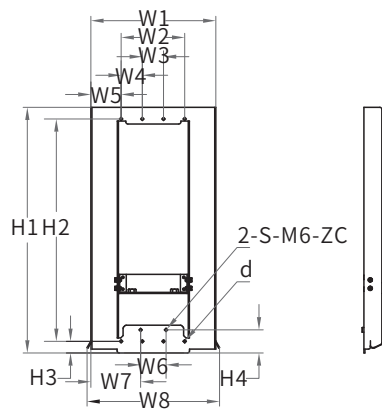

Base dimension drawing

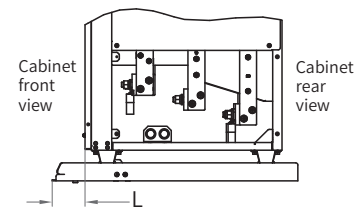
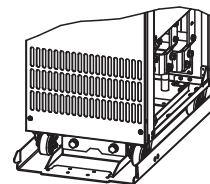
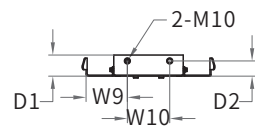

Base-to-cabinet installation layout

(unit: mm)

Frame	W1	W2	W3	W4	W5	W6	W7	W8	W9	W10	H1	H2	H3	H4	D1	D2	d	Screw	L
T10	295	150	50	50	71.5	60	117.5	313	97.5	100	580	525	27.5	54.5	50	36	6	M5 self-tapping screw	77.5
T11	321	150	50	50	84.5	60	130.5	339	110.5	100	580	525	27.5	54.5	46	33.5	6		25.5
T12																			25
T13	380	150	50	50	115	60	160	398	140	100	615	575	25	55	48.5	32.5	6		19

Floor mounting for cabinet models >>>

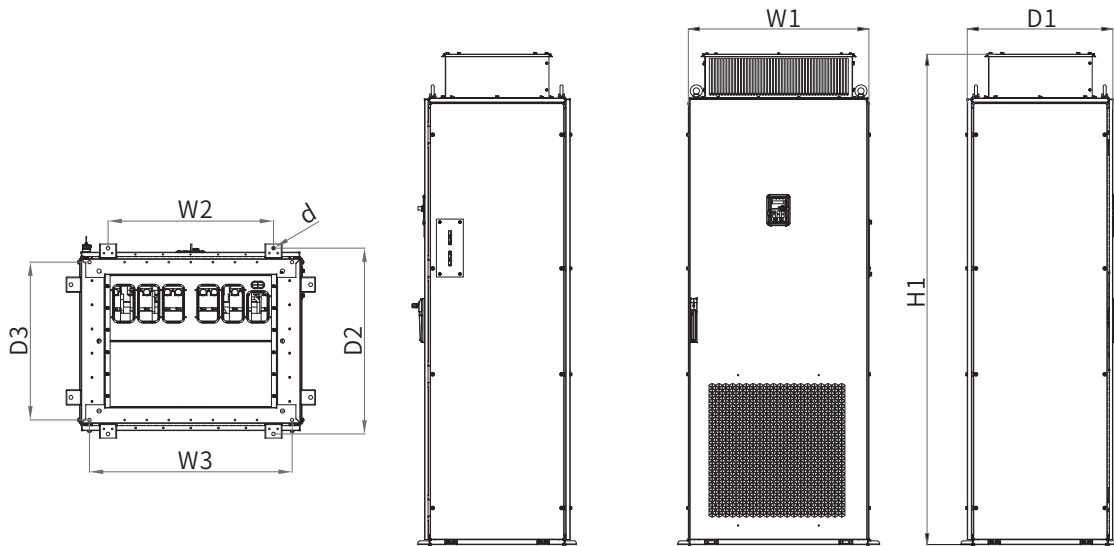

Floor mounting diagram for T14 frame

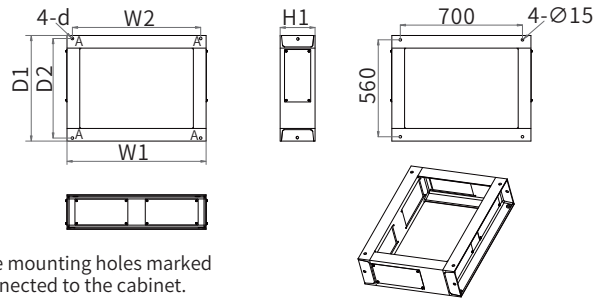

Note: The mounting holes marked A are connected to the cabinet.

Base dimension drawing (optional)

(unit: mm)

Frame	VFD model	Outline dimensions (mm)			Hole distance (mm)				Hole diameter (mm)	Screw
		W1	H1	D1	W2	W3	W4	D2		
T14	GD290-560G-4	806	2200	650	600	735	677	575	13	M12
	GD290-630G-4									
	GD290-710P-4									
	GD290-800P-4									
	GD290-560G-4-L3									
	GD290-630G-4-L3									
	GD290-710P-4-L3									
GD290-800P-4-L3										
T14	Base	797	200	610	735	/	575	/	15	M12×30 + spring and flat washer 12

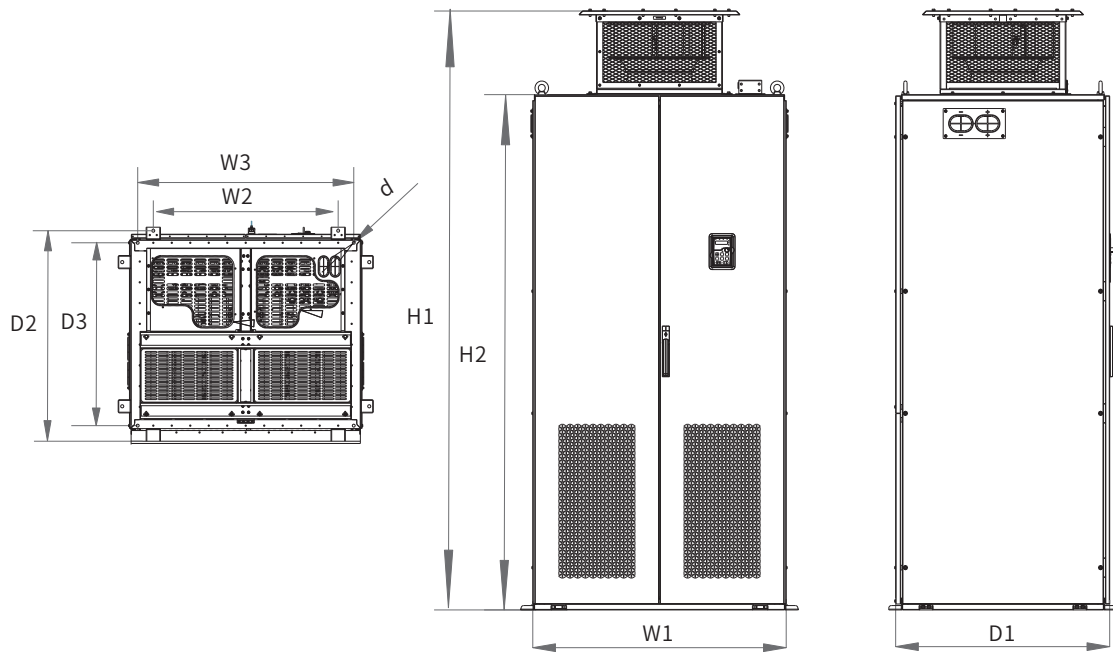

Floor mounting diagram for T15 frame

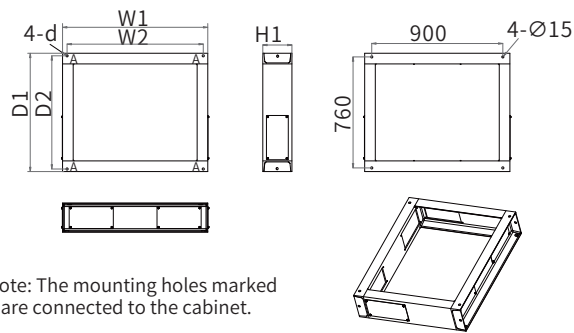

Note: The mounting holes marked A are connected to the cabinet.

Base dimension drawing (optional)

(unit: mm)

Frame	VFD model	Outline dimensions (mm)				Hole distance (mm)				Hole diameter (mm)	Screw
		W1	H1	H2	D1	W2	W3	D2	D3		
T15	GD290-710G-4	1006	2329	2004	850	800	935	877	775	13	M12
	GD290-800G-4										
	GD290-900G-4										
	GD290-1000G-4										
	GD290-900P-4										
	GD290-1000P-4										
	GD290-1120P-4										
GD290-1200P-4											
T15	Base	997	200	/	810	935	/	775	/	15	M12×30 + spring and flat washer 12

Flange mounting >>>

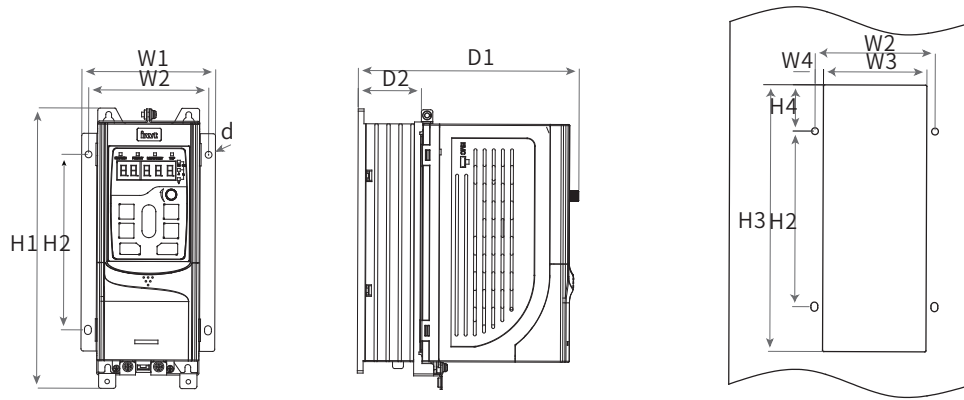

Flange mounting diagram for T1-T2 frames

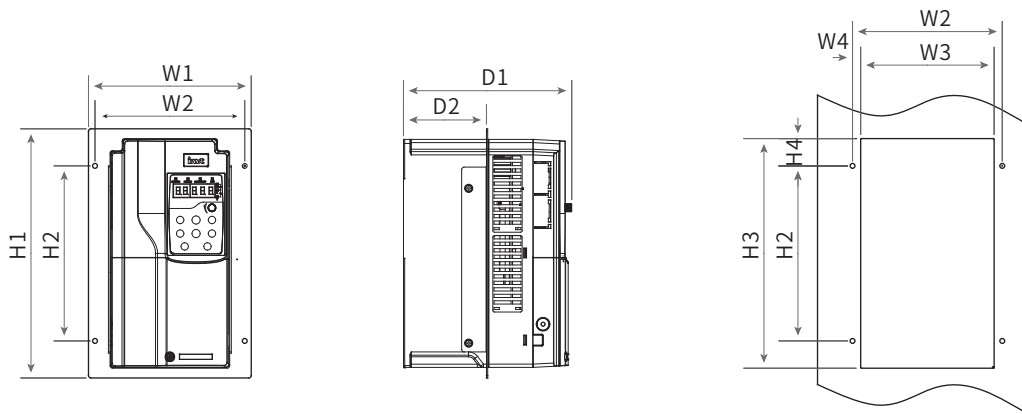

Flange mounting diagram for T3-T4 frames

(unit: mm)

Frame	VFD model	Outline dimensions (mm)			Hole distance (mm)							Hole diameter (mm)	Screw
		W1	H1	D1	H2	H3	H4	W2	W3	W4	D2		
T1	GD290-0R7G/1R5P-4	117	234	193	153.3	225	30	105	92.5	6.5	55	6	M5
	GD290-1R5G/2R2P-4												
	GD290-2R2G/003P-4												
	GD290-003G/004P-4												
T2	GD290-004G/5R5P-4	117	261	212	180	220	30	105	92.5	6.5	75	6	M5
	GD290-5R5G/7R5P-4												
T3	GD290-7R5G/011P-4	200	306	207	215	282	33.5	184	164	10	102	6	M5
	GD290-011G/015P-4												
T4	GD290-015G/018P-4	224	346	214	255	322	33.5	208	189	9.5	108	6	M5
	GD290-018G/022P-4												

Flange mounting >>>

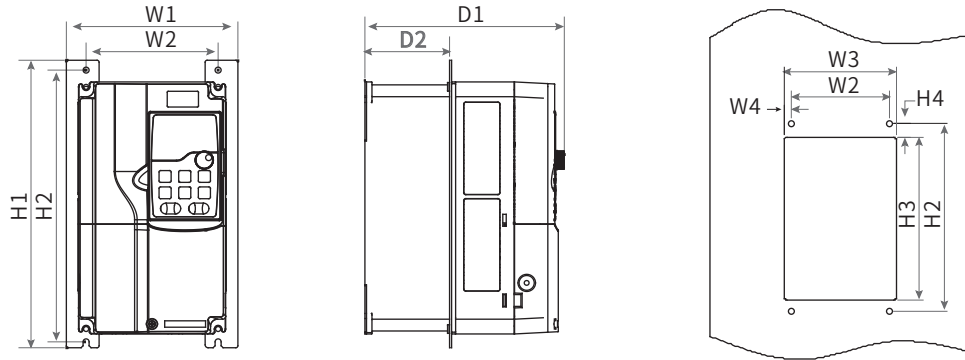

Flange mounting diagram for T5-T7 frames

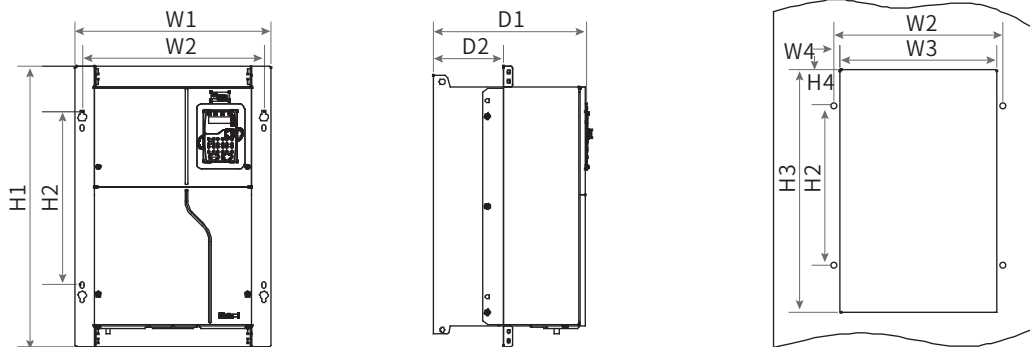

Flange mounting diagram for T8-T9 frames

(unit: mm)

Frame	VFD model	Outline dimensions (mm)			Hole distance (mm)							Hole diameter (mm)	Screw
		W1	H1	D1	H2	H3	H4	W2	W3	W4	D2		
T5	GD290-022G/030P-4	266	371	213	250	350.5	50.5	250	224	13	104	6	M5
	GD290-030G/037P-4												
T6	GD290-037G/045P-4(-B)	316	430	228	300	410	55	300	274	13	118.5	6	M5
	GD290-045G/055P-4(-B)												
T7	GD290-055G/075P-4(-B)	352	580	264	400	570	80.5	332	306	13	134	9	M8
	GD290-075G/090P-4(-B)												
T8	GD290-090G/110P-4(-B)	419	600	338	370	559	90	389.5	361	14	149.5	10	M8
	GD290-110G/132P-4(-B)												
T9	GD290-132G/160P-4	428	868	398.5	625	830	80	394	345	24.5	183	11	M10
	GD290-160G-4												
	GD290-185P-4												
	GD290-200P-4												

Leading Smart Industry, Shaping Net-Zero Future

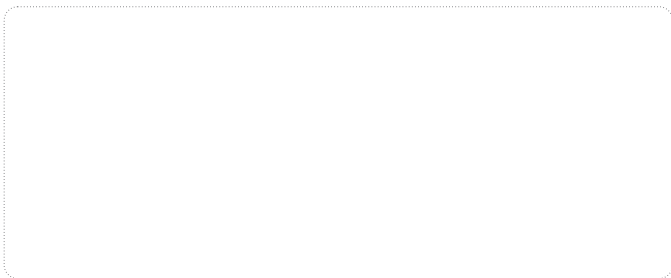

E-mail: overseas@invt.com.cn Website: www.invt.com

SHENZHEN INVT ELECTRIC CO.,LTD. INVT Guangming Technology Building, Songbai Road, Matian, Guangming District, Shenzhen, China

- Industrial Automation:**
- HMI
 - PLC
 - VFD
 - Servo System
 - Elevator Intelligent Control System
 - Rail Transit Traction System
- Electric Power:**
- UPS
 - DCIM
 - Solar Inverter
 - New Energy Vehicle Powertrain System
 - New Energy Vehicle Charging System
 - New Energy Vehicle Motor

INVT Copyright.
Information may be subject to change without notice during product improving.

66003-00418

202605(V2.0)